



CFD-modellering og 3D-scanning af overløbsbygværker

Lasse Sørensen, VCS
las@vandcenter.dk



VandCenterSyd

DIT VAND · VORES ELEMENT

Agenda

- Hvad er CFD
- 3D-scanning af bygværker
- Validering af CFD
 - Laboratorie
 - Virkelighedens verden
- Anvendelse af CFD



CFD

- CFD (Computational Fluid Dynamics)
 - 3D-strømninger med høj præcision
- Hvad kan det bruges til?
 - Qh-relation
 - Softwaresensor
 - Forståelse
 - ...
- Hvad kræver det?
 - Geometri
 - Hardware og software
 - Kompetencer

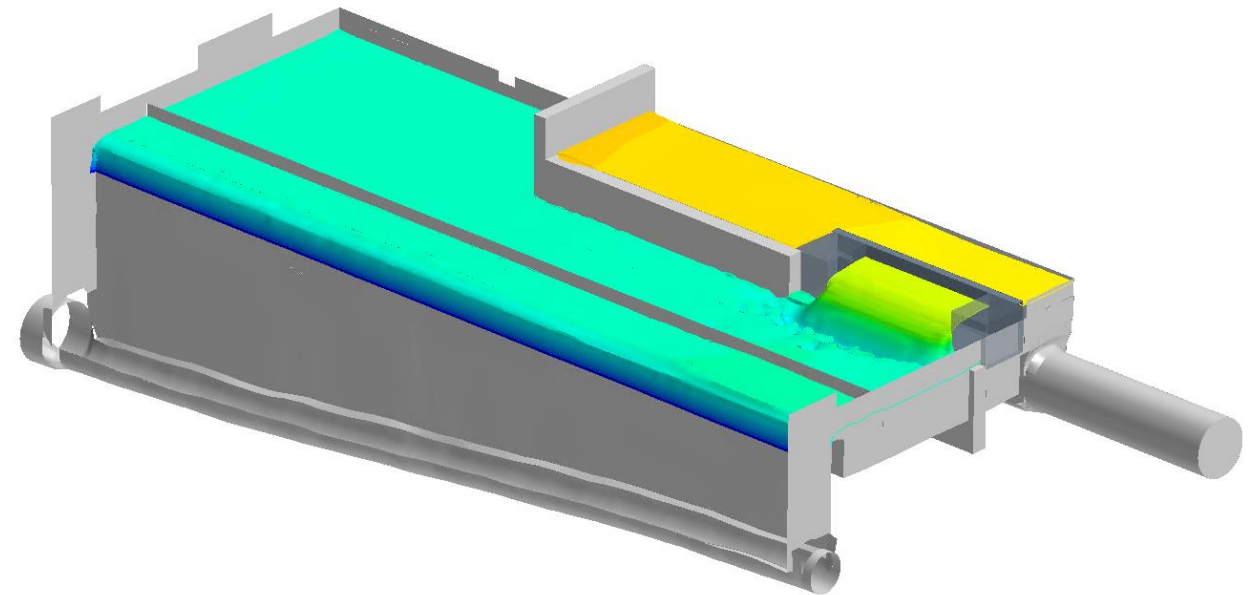



3D-scanning

- Bygværk spules og scannes ~15k-20k
- Præcision ca. 1 cm.
- Lukket geometri
 - stl.-fil

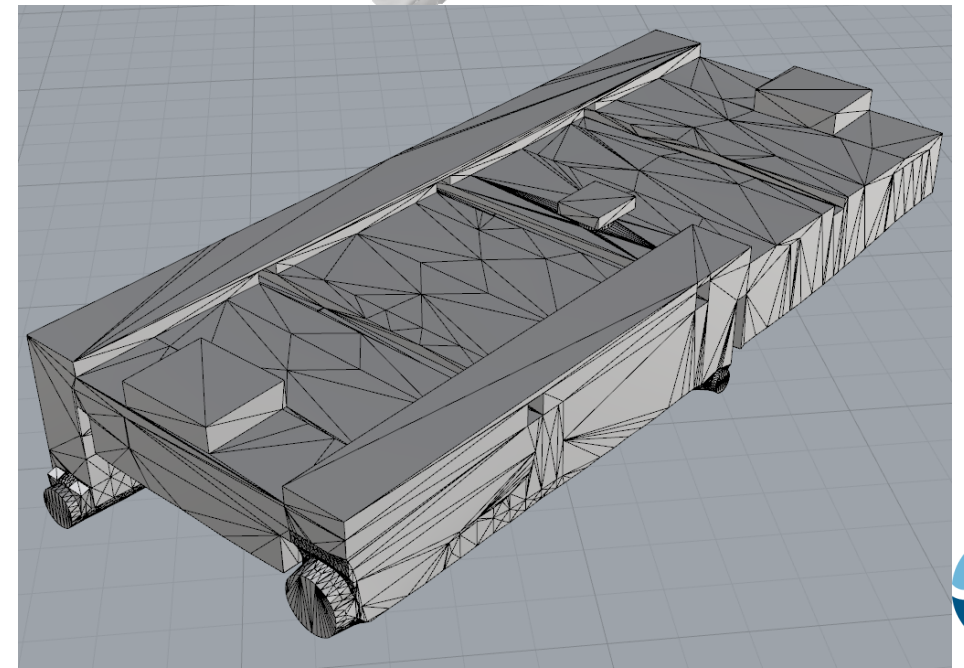
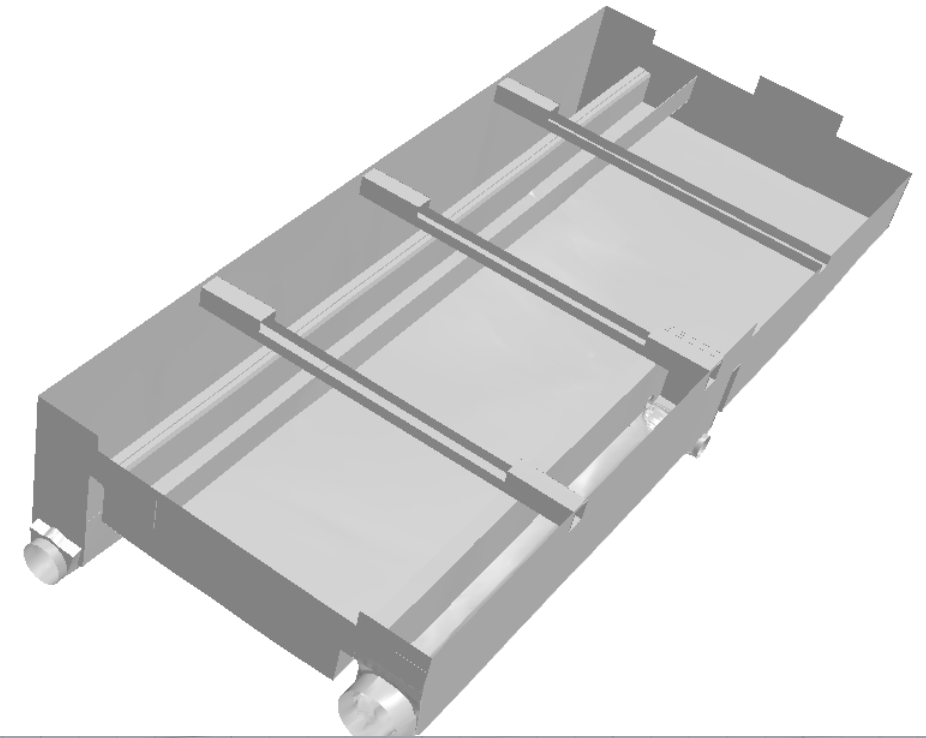

Laboratorieforsøg

- Forsøgsopstilling AAU

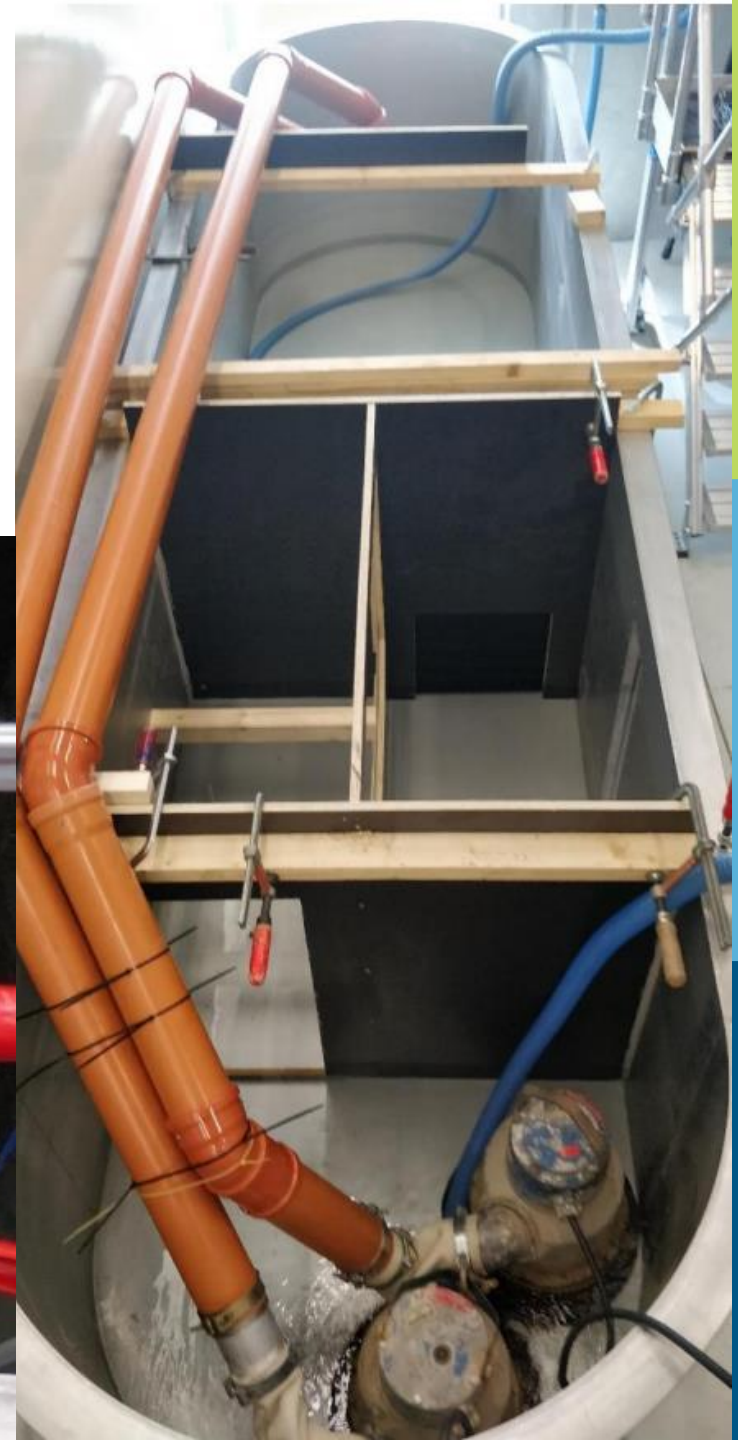

Sammenligning laboratorie

1. Vandret overløbskant

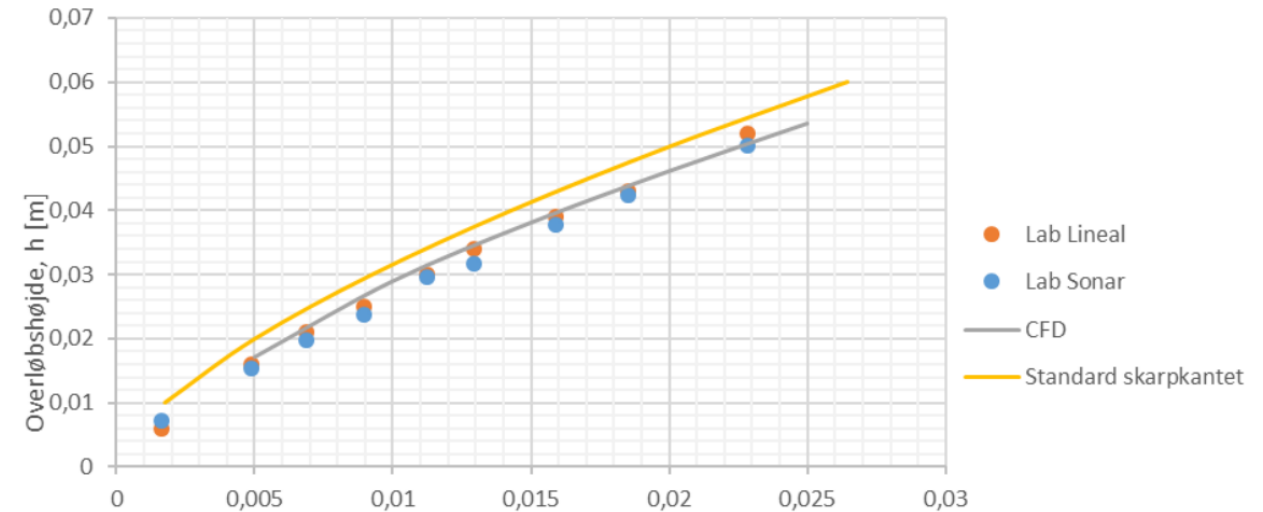

2. Hældende overløbskant

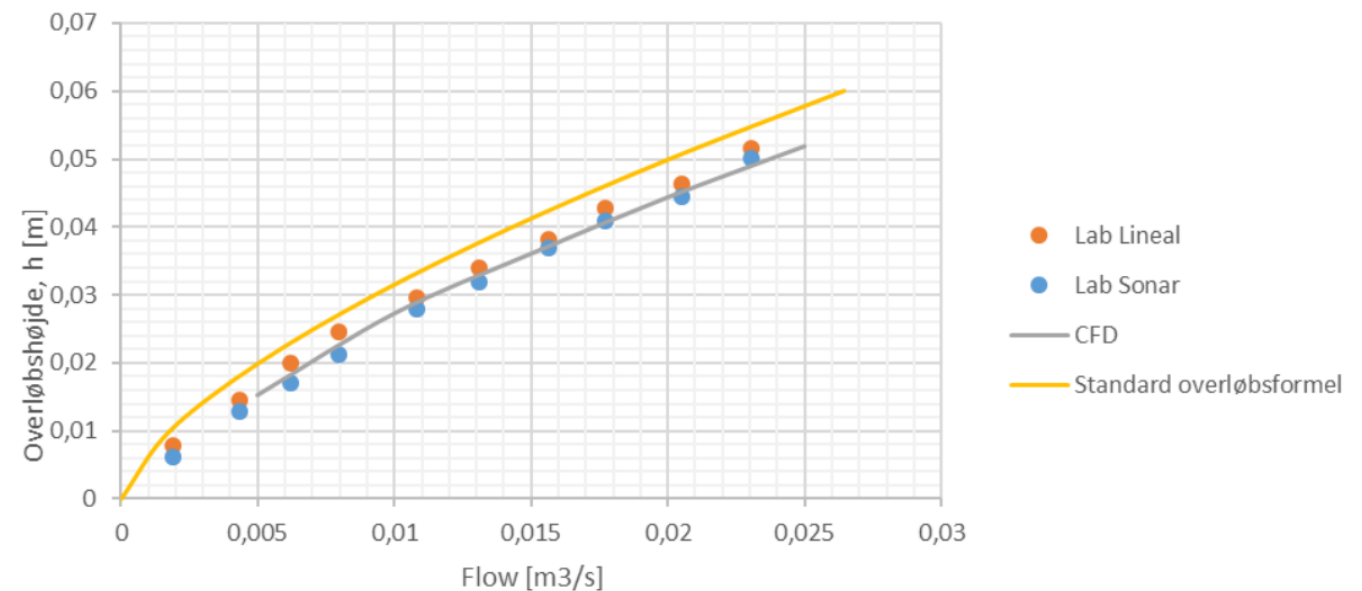

Eksempel Novafos, CFD fra Rambøll

- $Q = 1,43 \cdot l \cdot h^{1,44}$
 - l : længde af overløbskant
 - 24,75 m
 - h : overløbshøjde [m]

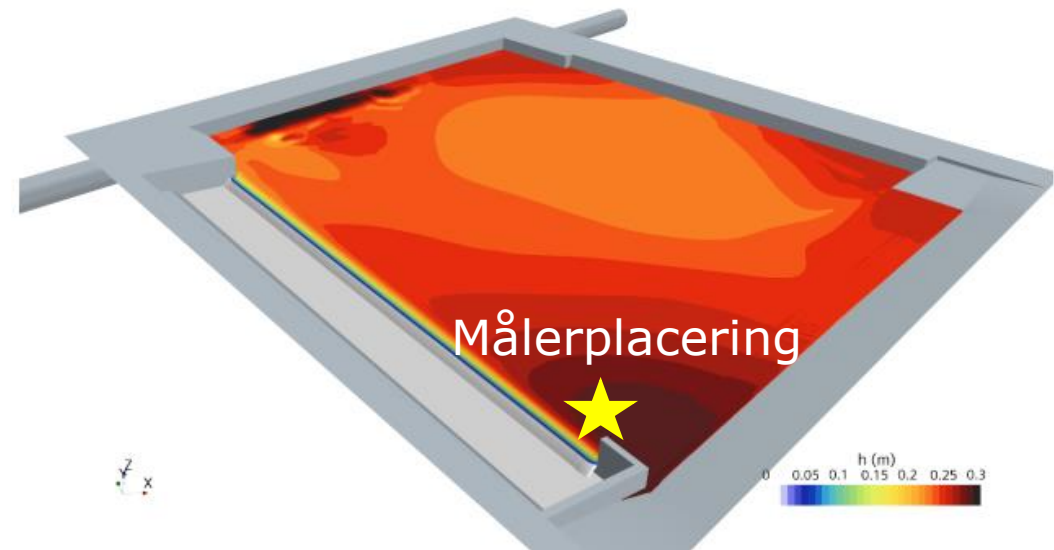
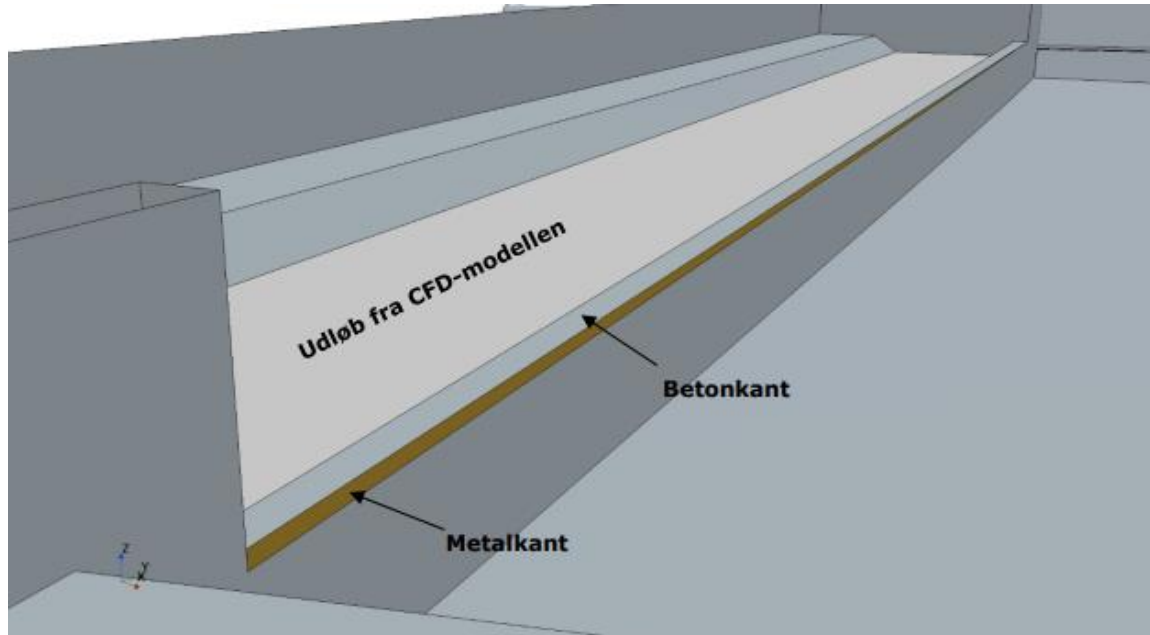

CFD og flowmåling

- Næst- og tredjestørste hændelse i 2022

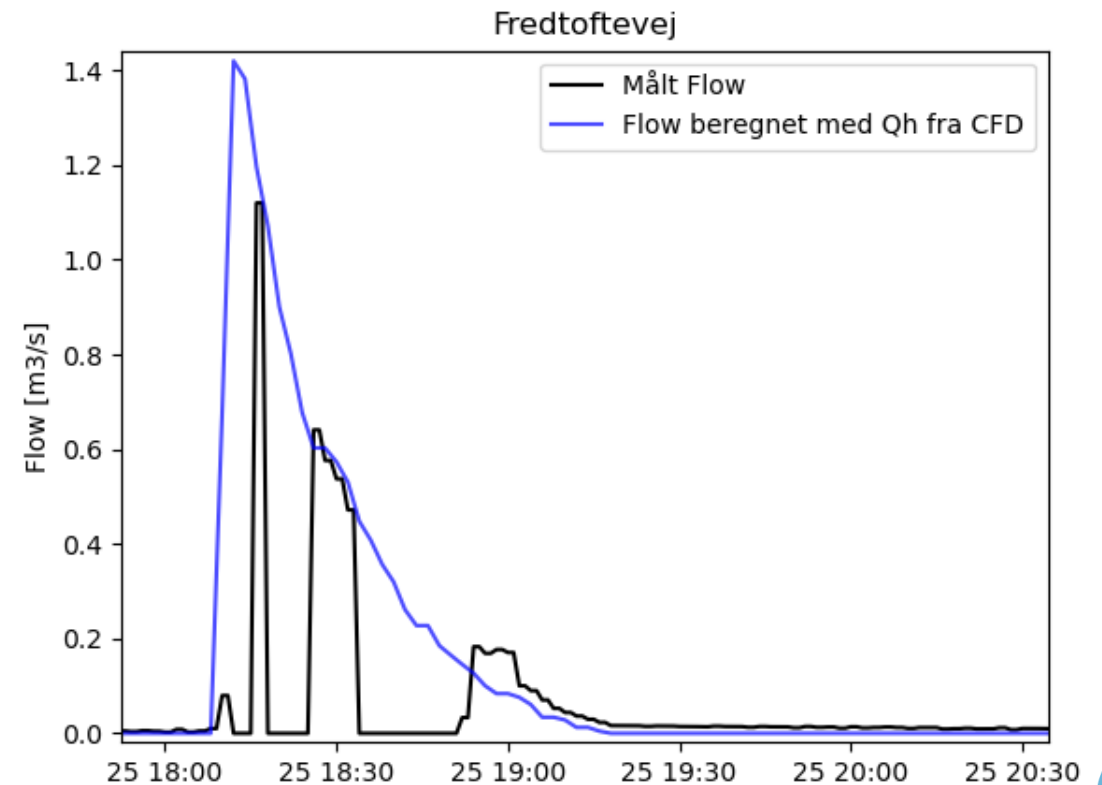
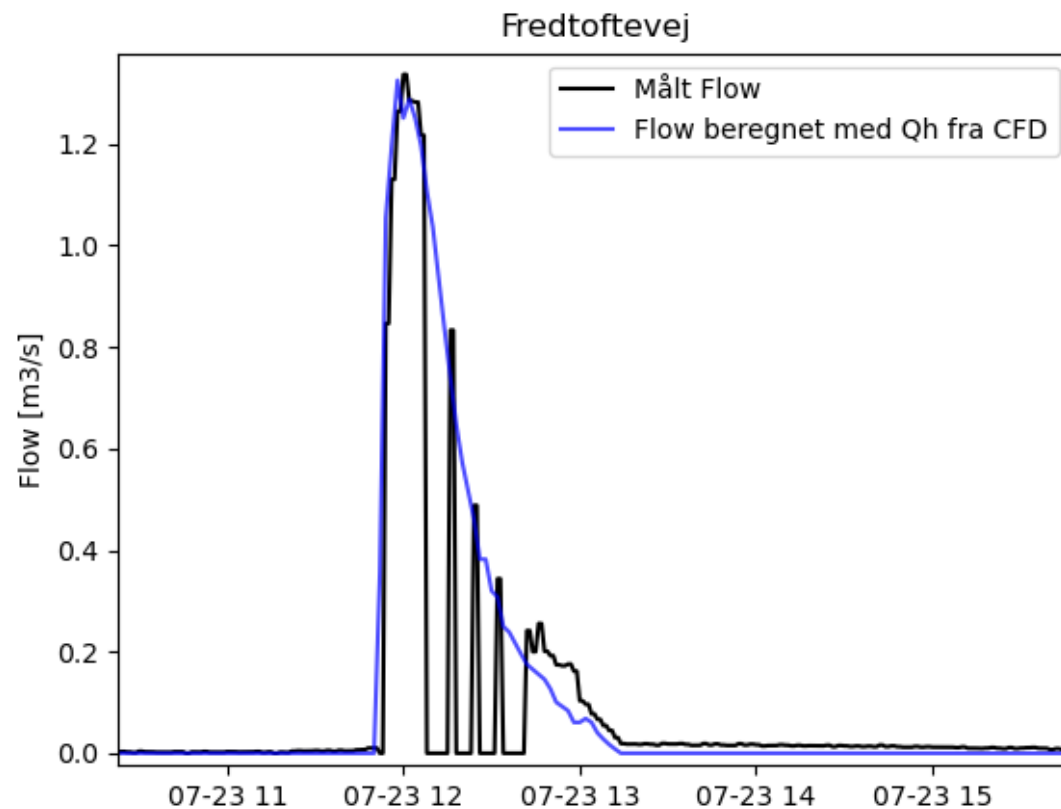

CFD og flowmåling

- Største hændelse 2022

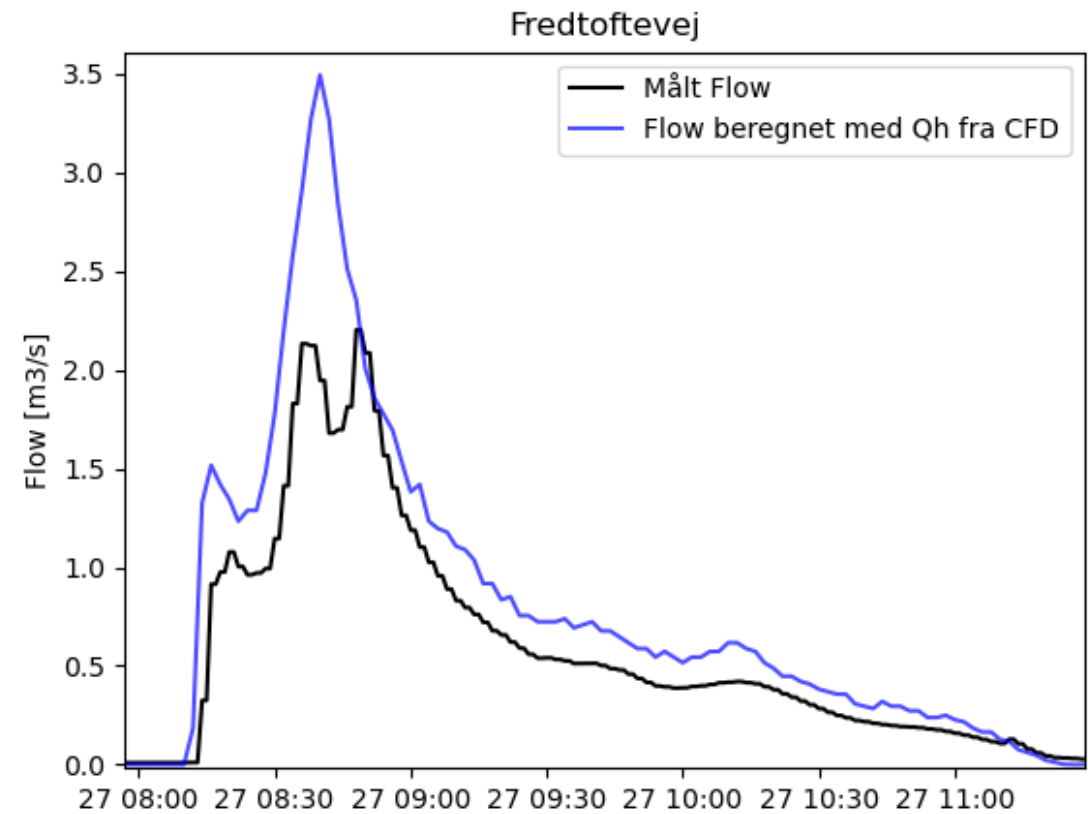
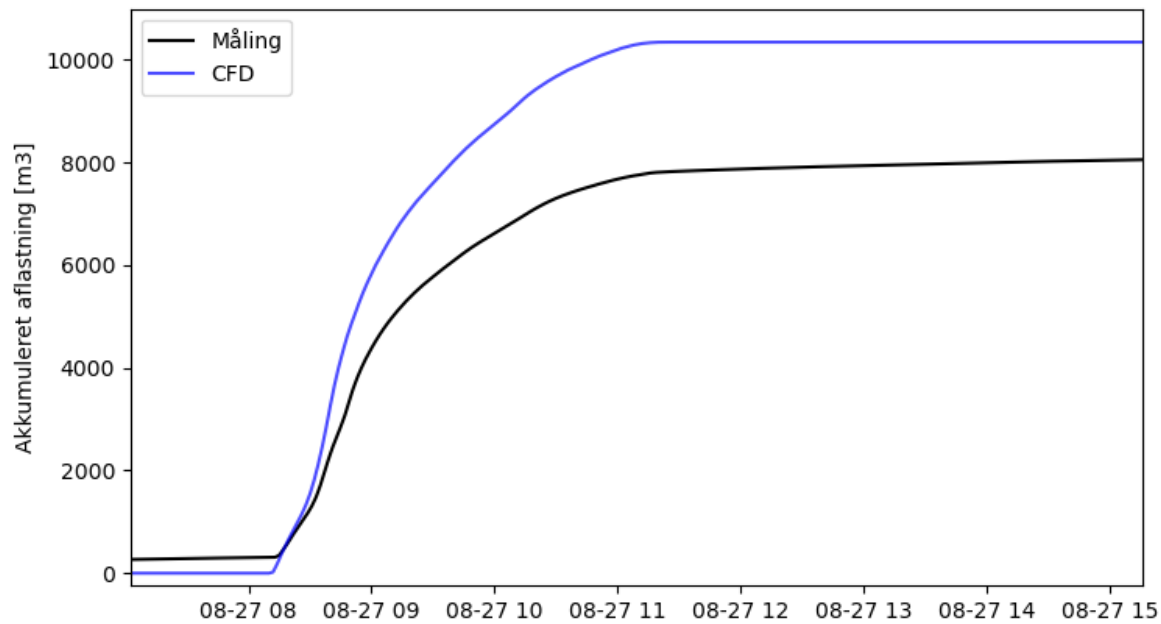

CFD og flowmåling

- Ledningskapacitet 8 m³/s
 - Enkelttab?
 - Luft?

Fredtoftevej

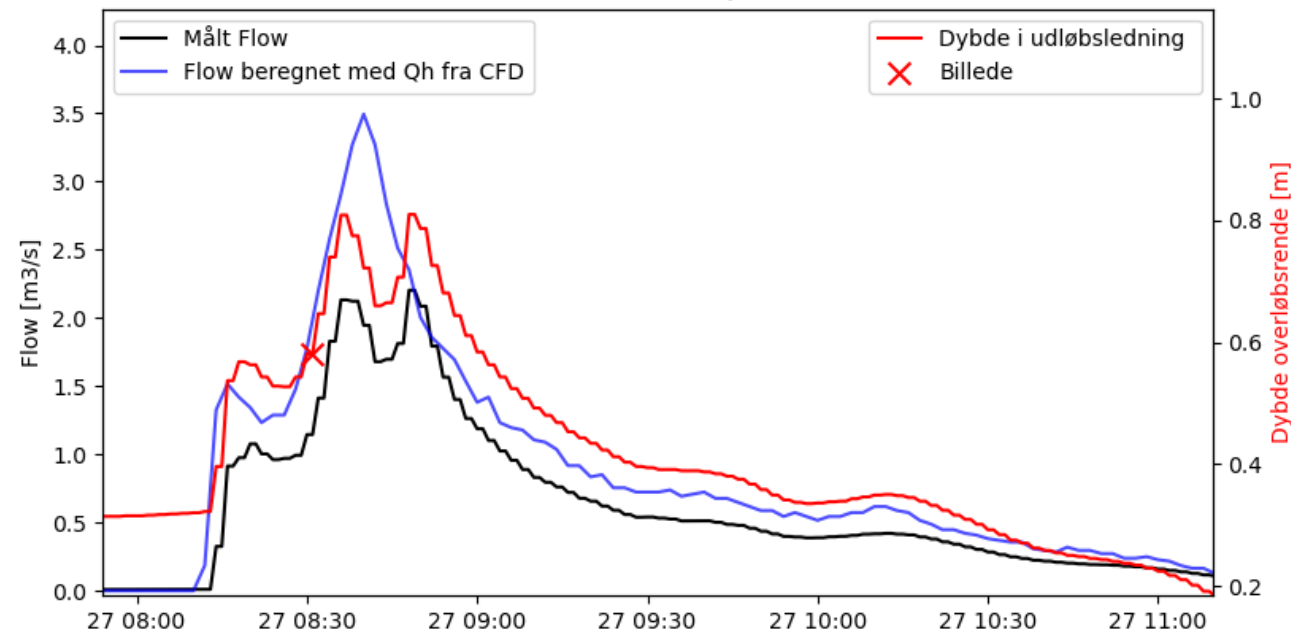

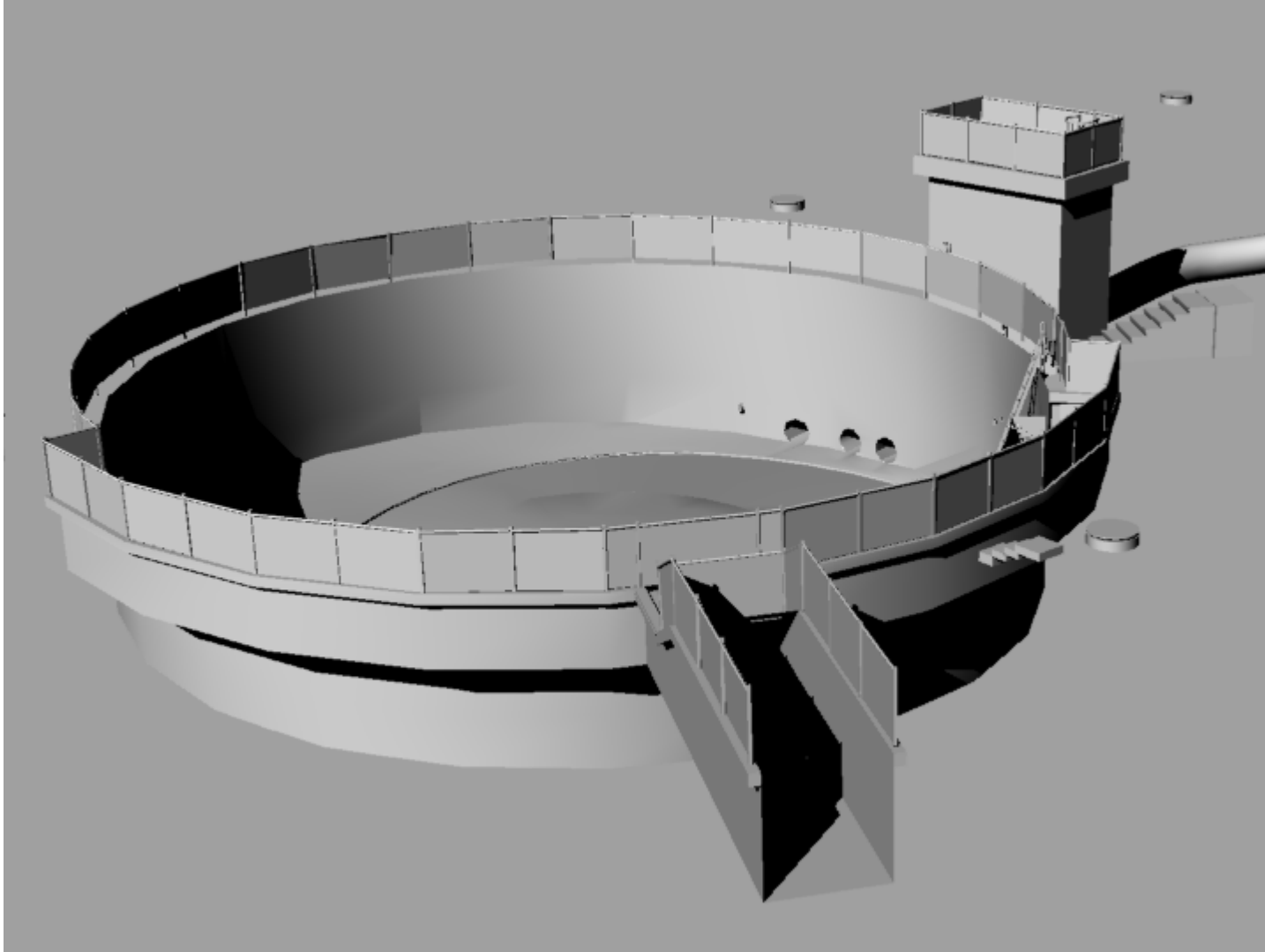

Qh-relation bygværk Odense

- Stort enkelttab os VCS

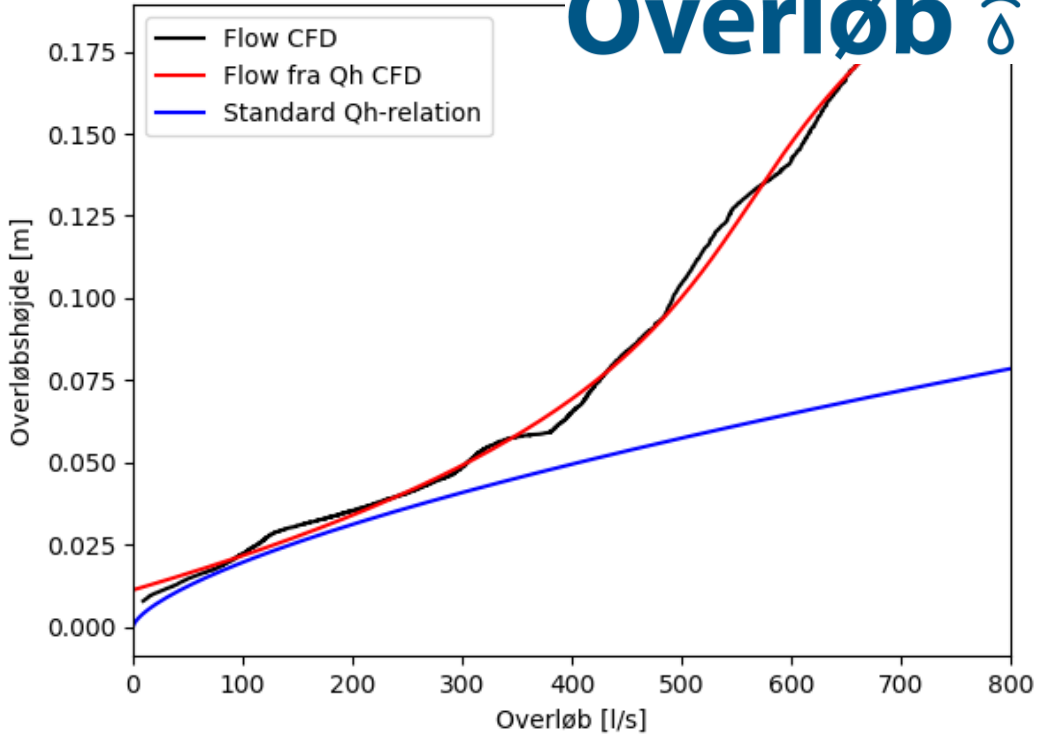

STAR-CCM+

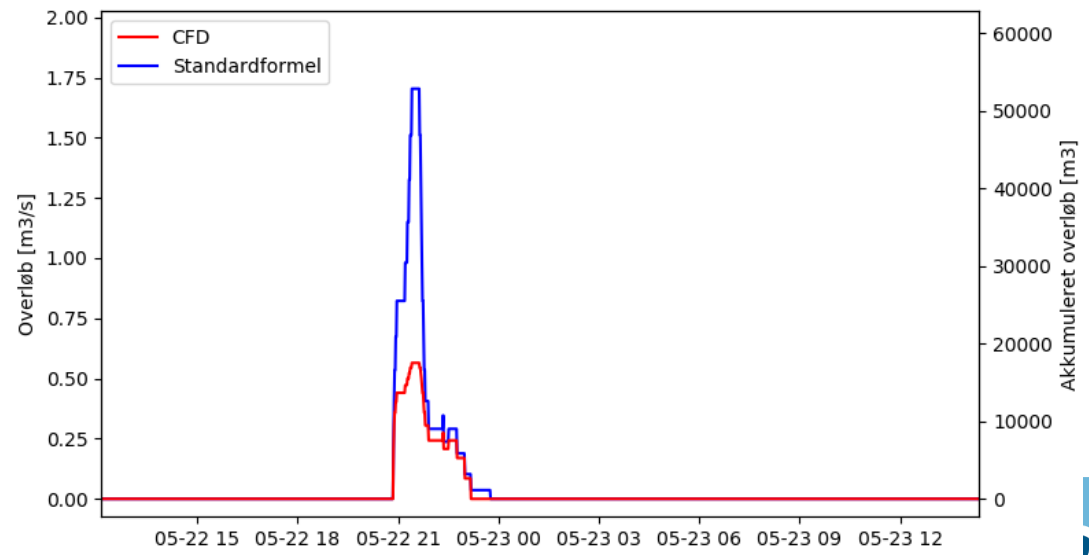
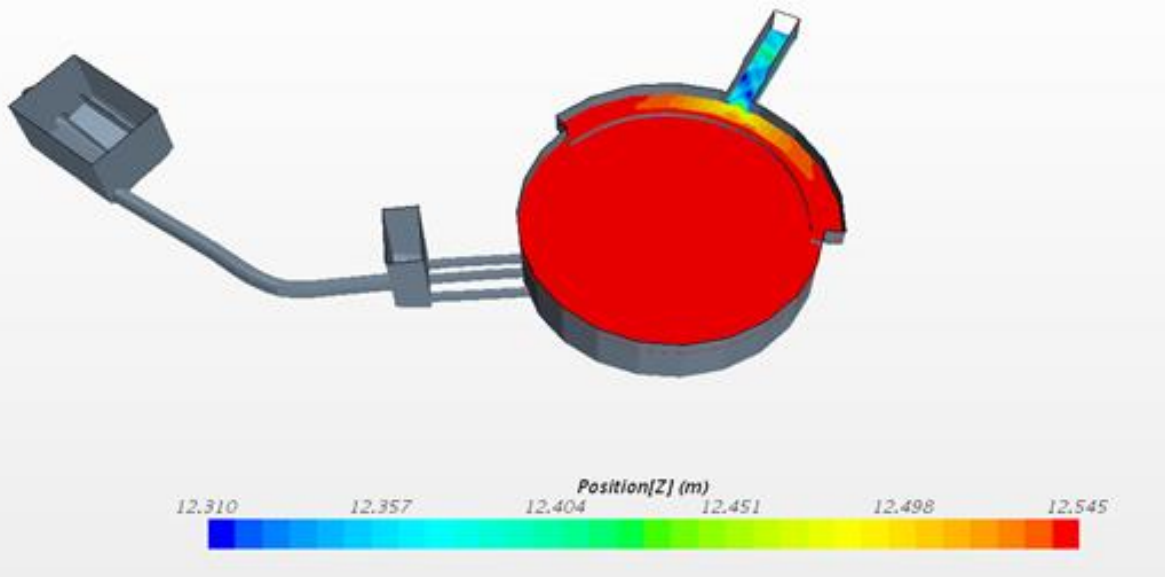

CFD VCS

- Usikkerhed ved små overløbshøjder
 - Årsmængde 49000m³
 - Årsmængde ved 1 cm forskel i placering 107000 m³

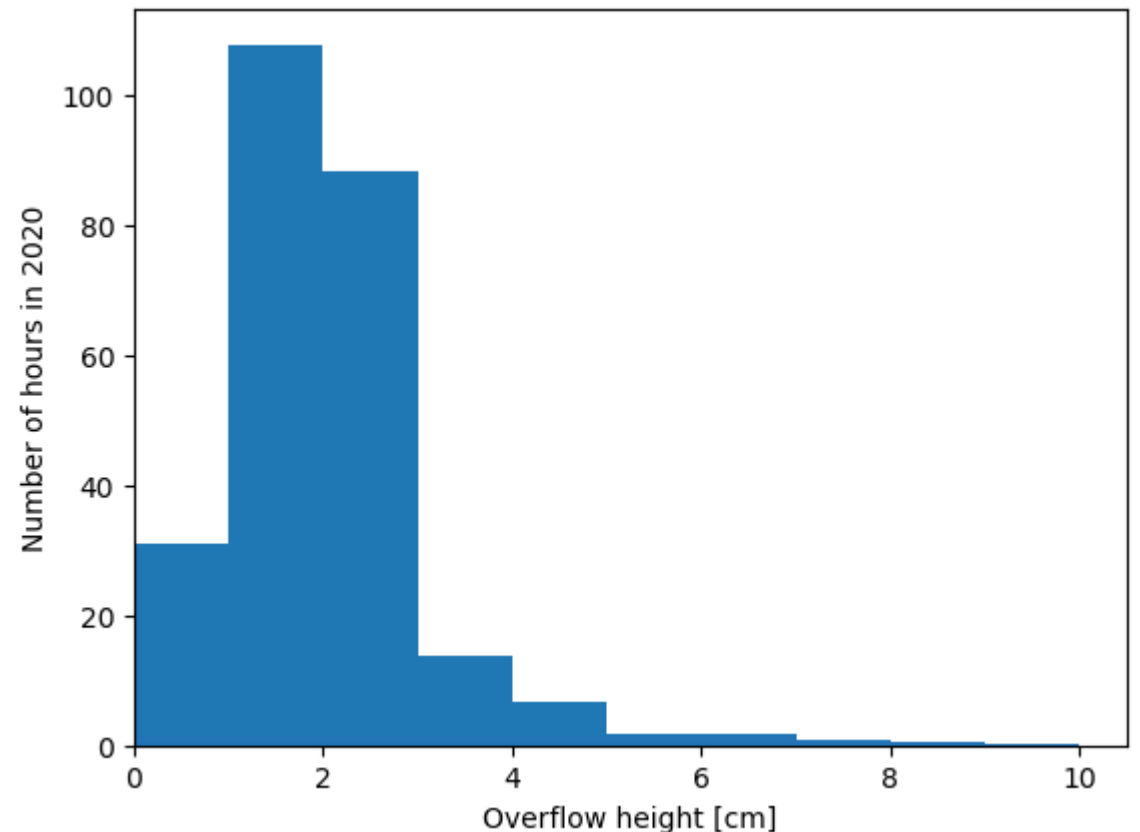
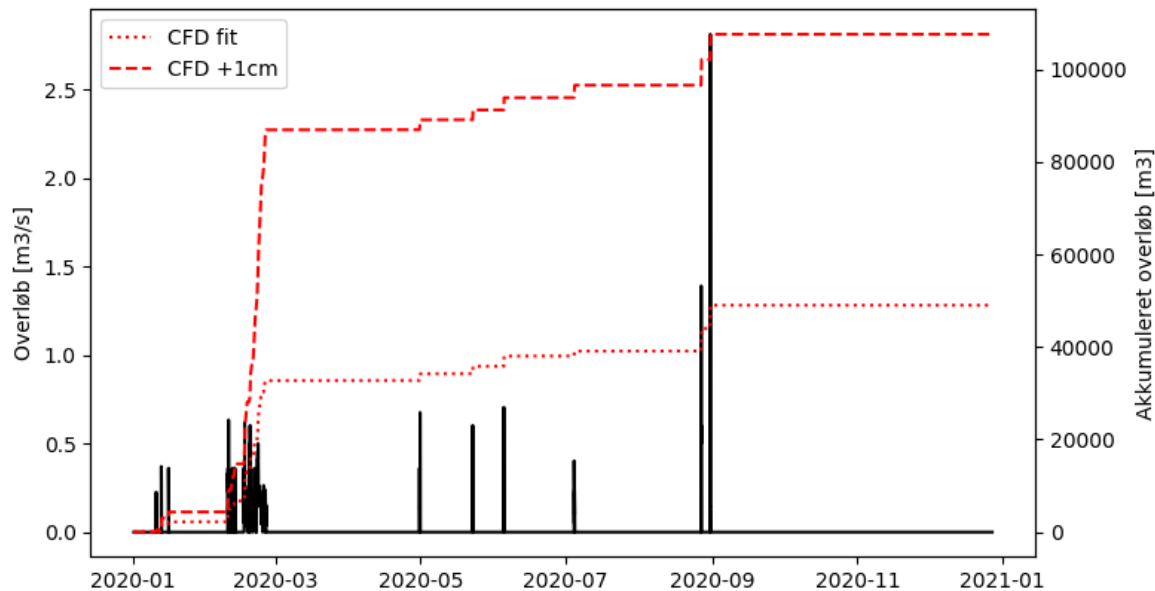

CFD til softwaresensor

- Små overløbshøjder giver usikkerheder
- Opmærksomhed på nedre randbetingelser
- Riste kan være udfordrende



CFD til ombygning

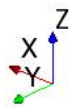
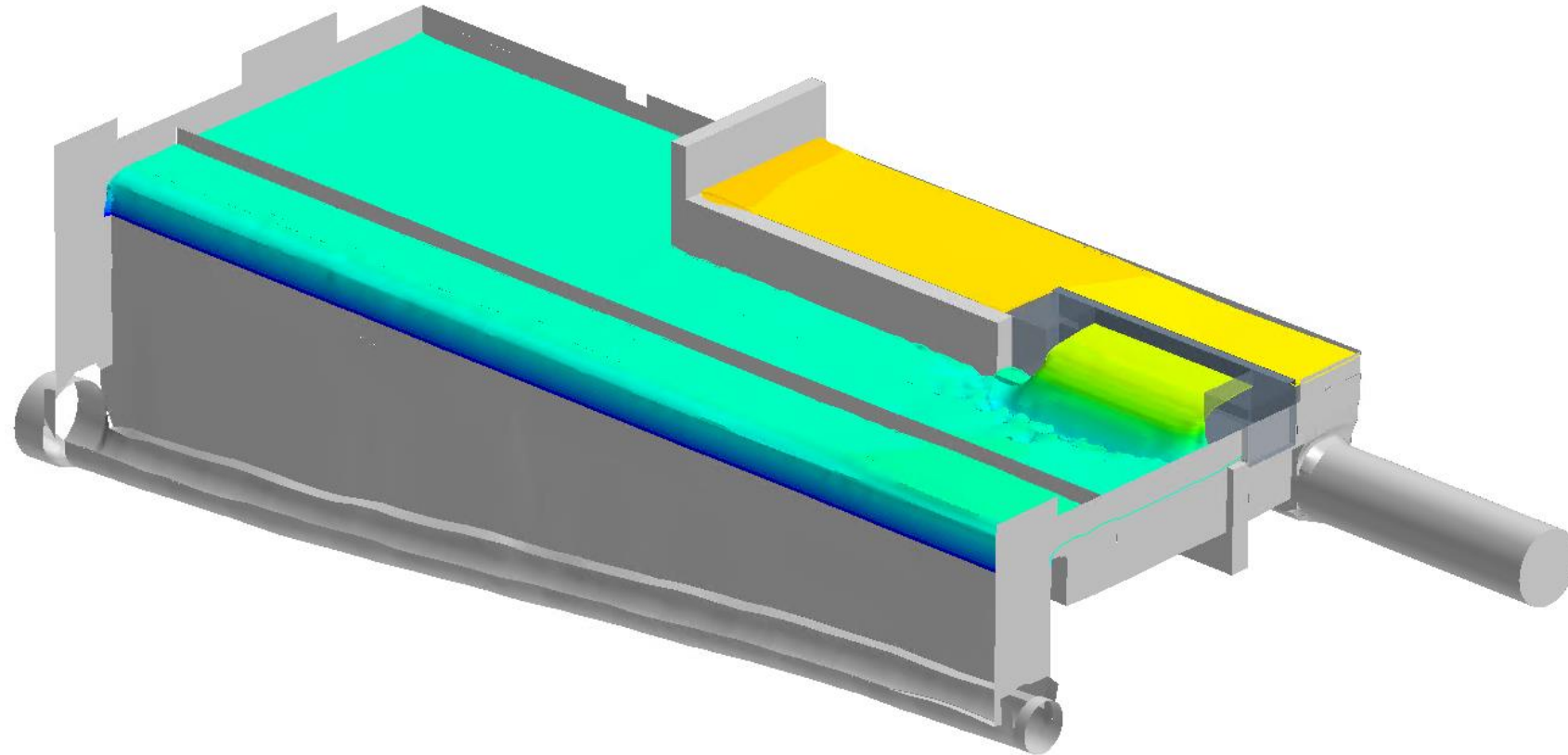



Tak for
opmærksomheden

Lasse Sørensen
las@vandcenter.dk